

XIV Configuration list

No.	Name	Specification	Quantity	Remark
1	Examination lamp	LED-5W	1	
2	Power adapter	4.2V-3A	1	
3	Accessories	<input type="checkbox"/> Fixed floor stand <input type="checkbox"/> Lifting floor stand <input type="checkbox"/> Table clip <input type="checkbox"/> Wall clip <input type="checkbox"/> Guide rail clip	1	
4	Standard parts	<input type="checkbox"/> M6x12mm Hand screw	1	
		<input type="checkbox"/> φ3x6mm countersunk head tapping screws	5	
5	Remote control	—	1	
6	User manual	A5	1	
7	Certification	—	1	

2025-02-28 version 1

KD-2005W-4 Medical Examination Lamp

USER MANUAL



NANJING YANAN SPECIAL LIGHTING FACTORY

Content

I Brief introduction.....	1
II Performance summary.....	1
III Main technical parameters.....	1
IV Security tips and symbol instructions.....	1
V Working environment.....	2
VI Product interface.....	3
VII Usage.....	4
VIII Attentions.....	6
IX Problem solution.....	7
X Bulb replacement.....	8
XI After-sales service and warranty.....	8
XII Transportation and storage condition.....	8
XIII Warranty card and maintenance card.....	9
XIV Configuration list.....	10

XIII Warranty card and maintenance card

Warranty card

Company name:			
Address		Phone No.	
Product name		Model	
Serial Number		Manufacture date	
Sale date			
Fault description:			
Remark: The warranty of our products is 18 months since release date. Please keep the certificate and instruction properly, and send it back with the product when repairing.			

(Please truthfully fill in this form, cut it according to the dotted line and send it back to our company, thank you for your cooperation)

Maintenance card

Company name:			
Address		Phone No.	
Product name		Model	
Serial Number		Manufacture date	
Sale date			
Fault description:			
Note: if you use this card beyond warranty period, you can enjoy 30% discount repair service.			

X Bulb replacement

The bulb is LED light source, normal life is up to 10000 hours, no need to replace normally. In case of any failure, please inform the manufacturer in time for processing.

XI After-sales service

- ◆ The product warranty period is 18 months
- ◆ During warranty period, send or give us your warranty card and purchase invoices, we will provide free maintenance service when you have quality problems.
- ◆ Light bulbs are consumable accessories.
- ◆ If you modified the function by yourself and then it does not work, is not covered under warranty.
- ◆ If the marks on the product such as model, serial number, date of manufacture has been altered, deleted, moved, or unidentifiable, will not provide free warranty service.
- ◆ Failure caused by human factors such as falling, squeezing, soaking and damp is not covered by the warranty
- ◆ The production date is shown on label, service life is 5 years, we provide lifetime maintenance.
- ◆ After-sales No.:+86-25-52777091
Telephone(WeChat):+86-13675197193

XII Transportation and storage condition

Environment temperature: -40℃~55℃

Relative humidity: 30%~80%

Atmospheric pressure: 500hpa~1060hpa

I Brief introduction

KD-2005W-4 medical examination lamp (hereinafter referred to as the "examination lamp") adopts 5W international brand high-power LED as the light source, featuring high brightness, high color rendering and high clarity. Through optical design, the light distribution is uniform, the image of the illuminated object is clear and bright, and there is no temperature rise. This product is composed of lamp head, lamp post, control box and power adapter.

Brightness of this product can be adjusted, hose can be bent, it can be multi-angle lighting. There are desktop, guide rail, wall type, floor type auxiliary parts for choice.

This product adopts wide voltage input, low voltage output power supply mode, with stable, safe and reliable performance. It is suitable for various outpatient departments in medical fields such as ENT, medical beauty, ophthalmology, etc.

II Performance summary

The design and production of the inspection lamp fully comply with GB9706.1-2020 "Medical Electrical Apparatus - Part 1: Safety - General Requirements", ensuring safety.

III Main technical parameters

1. Adapter rated voltage: AC100~240V, 50Hz/60Hz
2. Input power: ≤10VA
3. Product Specification: LED-5W
4. Product color temperature :5300±500K

V Security tips and symbol instructions

1. When the examination lamp is in use, to avoid the risks of fire, electric shock or personal injury, basic safety precautions should always be followed.
2. Please read the instructions carefully and follow the instructions.

3. Maintenance of the lamp must be operated by professional personnel. It is recommended that the operator wear an electrostatic ring to work.
4. Turn off the main power supply when its not in use.
5. Before cleaning the lamp, turn off power and unplug, do not use liquid or spray cleaner.
6. Do not use this product near water. Do not press anything on the power cord.
7. Before replacing bulb, turn off power switch and unplug power cable.
8. Brightness of the lamp is very high, do not observe with eyes in front to prevent eye damage.
9. Illustration of symbols:



V Working environment

Environment temperature: -5℃ ~40℃

Relative humidity: 35%~75%

Atmospheric pressure:700hPa~1060hPa

5. It is strictly prohibited to hang any items other than this equipment on the lamp body.
6. At the end of daily use, it can be irradiated by ultraviolet lamp for elimination. Note: do not use spray liquid disinfect.
7. Each month, use 75% alcohol cotton to remove dust on the surface of the lamp [Note: when cleaning, prevent liquid from seeping into lamp].
8. Conduct a comprehensive inspection of nut, switch, brightness and noise of the lamp every quarter, timely repair and adjustment if any abnormality is found.
9. Bulbs are consumables and have a basic life span. The normal life of LED bulb is about 10000 hours. Pay attention to how long bulbs are used and prepare for them in advance.
10. The service life of the inspection lamp is five years. After the expiration, if it is scrapped, its metal, electronic components, plastic, glass and other materials should be uniformly and strictly treated in accordance with local environmental protection regulations to prevent their spread or reuse, minimizing the risk of environmental pollution.

IX Failure judgment and eliminate (This requires professional operation)

Phenomena	Reason	Solution
Lamp doesn't work	1. Power supply line is Disconnected.	Switch to a live supply line
	2. The power plug is not properly connected to power socket ⑨.	Reconnect the power plug
	3. The lamp switch is not turned on.	Press switch ⑥ to turn on the light
	4. The light spot is the minimum.	Rotate the spot adjustment ring ② to enlarge the spot
	5. The lamp beads are damaged.	Replace bulb with the same specification.
	6. The power adapter is damaged.	Replace power adapter with the same specification.

5)When the T-shaped plug-in at the bottom is loose and cannot be positioned, you can rotate the locking handle⑦ clockwise. You can also loosen it, adjust the tilt position of the lamp body, and then lock it.
6)When the locking handle ⑦ cannot be operated due to position limitations, you can hold the locking handle ⑦ and lift it outward while adjusting the direction of the handle at the same time, as shown in Picture 4. After letting go, you can perform operations such as locking and releasing.



Picture 4

7)This examination lamp is equipped with remote control operation. The buttons on the remote control have the same functions as those on the examination lamp body. The remote control range is 3 to 5 meters from the front of the receiver.

VIII Attention

- 1.The lamp should be assembled and reinforced according to technical requirements in the manual.
- 2.Installation and debugging of the lamp should be completed by professionals.
- 3.Put the old replaced bulbs in waste bucket, do not throw it about.
- 4.When the lamps are used in conjunction, do not pull the lamp heads or lamp poles severely.

VI Product interface

1.The product interface of the examination lamp (Picture 1) :

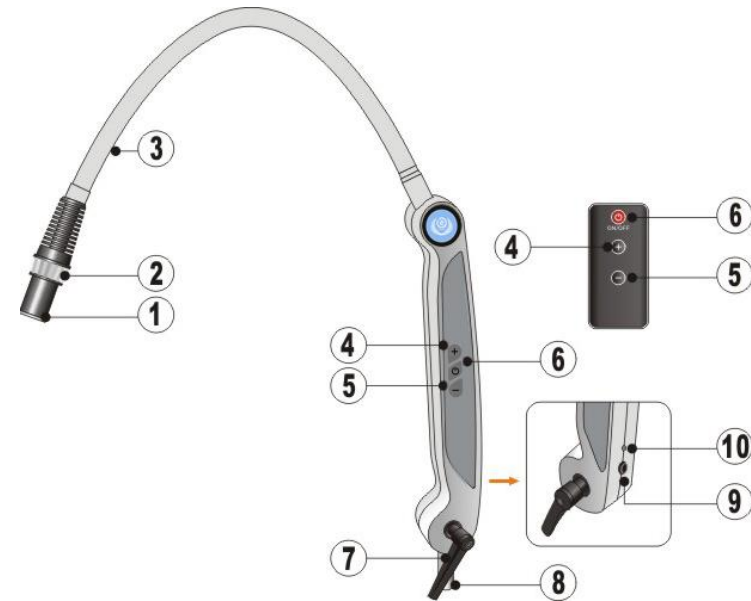

- ①Lamp head ②Spot adjustment ring ③Hose ④Brightness increase
⑤Brightness decrease ⑥Switch ⑦Locking handle ⑧T-shaped plug-in
⑨Power socket ⑩Receiver

Picture 1

2. Accessory interface:

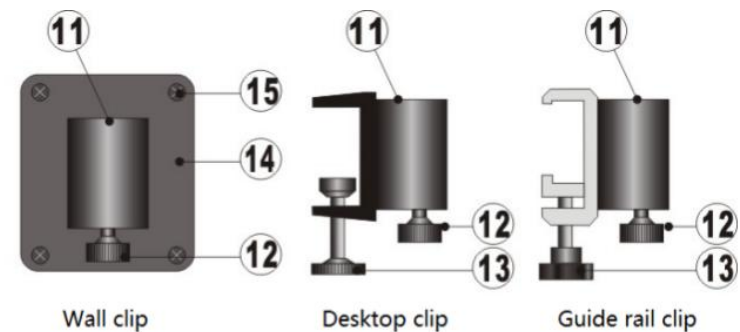

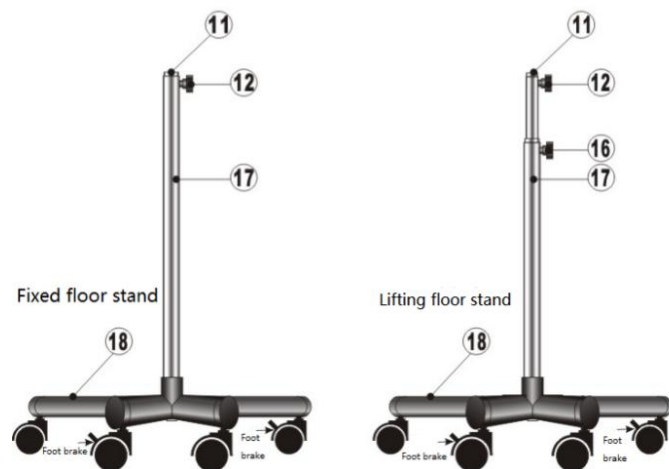

⑪T-shaped piece jack ⑫T-shaped plug-in locking screw ⑬Escaping screw ⑭Wall mounting base plate ⑮Base plate fixing screw ⑯Lifting rod locking screw ⑰Column ⑱Foot roller

Picture 2

VII Usage

1. Check before use

- 1)Unpack and check whether the product is damaged or missing parts
- 2)According to the Configuration List, check whether the product model, name, quantity and accessories are consistent with the Configuration List;If any problem is found, please contact manufacturer in time.
- 3)Read the instructions carefully and follow the installation steps.

2. Installation and use

1)Wall-hanging clamp installation: Select an appropriate position on the wall, drill four mounting holes with diameter of 6mm and depth of 30mm according to the dimensions shown in picture 3-1, install expansion tube, and install wall mounting base plate⑭ on the wall with self-tapping screws with diameter of 4mm (see picture 3-1、2). Butt T-shaped plug-in⑧ with T-shaped piece jack⑪ and tighten T-shaped plug-in locking screw⑫.

4

2)Table and guide clamp installation: put the mount into appropriate position of table top or guide rail, tighten escaping screw⑬, butt T-shaped plug-in⑧ with T-shaped piece jack⑪, and lock T-shaped plug-in locking screw⑫.

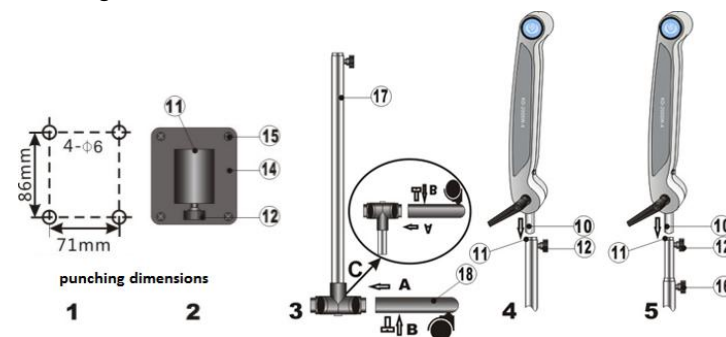

Picture 3

3) Installation of fixing bracket and lifting bracket:

(1) Bracket assembly: First, align the five claws at the bottom of the column⑰ and the five foot roller ⑱ one by one in the direction of arrow A in Picture 3-3. Then install and tighten fixing screw in the direction indicated by arrow B.

(2) Lamp installation: butt T-shaped plug-in⑧ with T-shaped piece jack⑪ according to the method shown in picture 3-4、5, then tighten T-shaped plug-in locking screw⑫.

3.Method of use

- 1)Connect the power adapter to the network power supply and power socket⑨, turn on power switch⑥, then the lamp starts to work.
- 2)Rotating the spot adjustment ring② can change the size of the spot.
- 3)This examination lamp has three levels of brightness adjustment, and the brightness is the maximum each time it is turned on. Pressing the brightness decrease button⑤ can decrease the brightness. Pressing the brightness increase button④ can increase the brightness.
- 4)Hold the lamp head with one hand and the lower end of the hose with the other. You can bend the hose at any angle to change the lighting Angle and position.

5